

INTERNATIONAL JOURNAL FOR ADVANCE RESEARCH IN ENGINEERING AND TECHNOLOGY

WINGS TO YOUR THOUGHTS.....

Advanced Security Guard with PIR Sensor for Commercial and Residential use

Sarvesh Suhas Kapre¹, Saurabh Sahebrao Salunkhe², Rohan Manoj Thakkar³,
Akshay Prakash Pawar⁴, Omkar Ashok Malusare⁵

¹K. J. Somaiya College of Engineering, Student of Computer Engineering Department,
Vidya Vihar (E), Mumbai 400077, India

sarveshk1808@gmail.com

²K. J. Somaiya College of Engineering, Student of Computer Engineering Department,
Vidya Vihar (E), Mumbai 400077, India

saurabh.salunkhe81@gmail.com

³K. J. Somaiya College of Engineering, Student of Computer Engineering Department,
Vidya Vihar (E), Mumbai 400077, India

rohan.m.thakkar@gmail.com

⁴K. J. Somaiya College of Engineering, Student of Computer Engineering Department,
Vidya Vihar (E), Mumbai 400077, India

akshay070993@gmail.com

⁵K. J. Somaiya College of Engineering, Student of Computer Engineering Department,
Vidya Vihar (E), Mumbai 400077, India

omkarmalusare89@gmail.com

Abstract: Automation and Security have become prime concerns in our everyday life. There is a standardized approach to automation of home and industrial equipment these days. We worked on this project with two major goals, that is, to (A) provide security to shops, residential areas, factories, banks and many other places of importance which it to be guarded from theft and (B) to cover all the area meant for protection and not to restrict the view to any single area of entrance. Through this paper, we have attempted to revamp these standards by fusing new techniques for design. Here, we have integrated a cost-efficient automated security system for domestic and industrial purposes. Highest levels of security are always desirable to everyone. The designs of hardware circuit allows each user to deploy this home security system on wireless connectivity using Gas sensor, PIR sensor, Main fuse Failure Detector and Smoke sensor at houses & industries. The system is 100% controlled by the 8-bits P89V51RD2 microcontroller. Each detector and sensor is interconnected with the microcontroller chip with the help of different types of interface circuits. The microcontroller chip will incessantly supervise every sensor. In case the microcontroller senses any type of security problem, then it will send an SMS message to the registered user mobile that uses GSM modem. Microcontroller circuit also switches ON and OFF the electrical appliances at houses and industries based on SMS messages received from the GSM modem of the user.

Keywords: Security Systems, PIR Sensor, Gas Sensor, Smoke Sensor, Fuse Failure Detector, RS-232 Interface Circuits, SMS (Short Message Service), GSM Communication

1. INTRODUCTION

The nature and complexity of the software systems had changed significantly in the last 30 years. The previous applications run on single processor and produce fixed output. But with the advancement in the technology application are having the complex user interface and these applications run on the various systems simultaneous like applications which support client server architecture.

Home security is the most significant one for every homeowner either in an individual house or an apartment. To get the absolute peace of mind whether you are at first time home or out of home you must ensure that your home is installed with the perfect home security monitoring system. This wireless home and industrial automation and security system can be used to provide security system for residential, industrial, and for all domestic and commercial purposes using GSM technique [7]. Security systems basically are nothing but certain form of electronic devices that can be used to identify threats or attacks at house or firm [9] [10]. The most basic components at a domestic automation system are LPG detectors, motion detectors and smoke detector. Through this paper, we put forward our work that attempted to overcome such flaws made by older security devices. The

device we formulated is highly effective in security purposes. It is cheaper and can be maintained easily than any other security device. This device works in two way modes-

- a. Internal mode
- b. External mode

When the internal mode is selected by the user when they are inside the wireless security area, the entire sensor except PIR sensor will be activated and the buzzer connected with the microcontroller will give an alarm and the reason for the insecurity will be displayed in the LCD connected to the microcontroller. In this mode, the electrical appliances in the security area automatically change to the manual mode in which user will control it.

When the external mode is selected by the user when they are outside the wireless security area, all the sensor will be active and the security area address which is pre-programmed, along with the problem will be sent as SMS to the specified police station, fire station, security room and also to the user at the time of insecurity, fire accident, unwanted movement of persons etc. which is sensed by the respective sensor. In this mode, the electrical appliances in the security area will automatically change to the automatic mode in which user will control it via SMS [8].

INTERNATIONAL JOURNAL FOR ADVANCE RESEARCH IN ENGINEERING AND TECHNOLOGY

WINGS TO YOUR THOUGHTS.....

2. LITERATURE REVIEW

2.1 Need for Security Systems

Each business owner attempts to protect their assets, employees and office space. We have worked to develop and maintain our businesses. Whenever one leaves, one wishes to ensure that everything is secured from malicious attacks. There are several techniques to help improve security levels at a business firm. One of the most efficient solutions is installing a security system that is self-monitored.

- Window Contacts and Door

Security contact is an easy and reliable form of security that could be installed swiftly. These security contacts will trigger an alarm once an intruder opens any window or door whenever the system remains activated. All those contacts get installed on each connection point at doors and windows. When they are in contact, the alarm will not go off, but it will when they unexpectedly lose contact.

- Motion Sensors

The purpose of motion Sensors is to detect intruders, whether inside the premises or outside. One can connect those to either the lights that work outside the building or to one alarm so that the alarm will alert you whenever an intruder lurks into the premises. Special motion detectors allow facilities with respect to pets. Most importantly, these motion sensors are able to be activated or deactivated as and when required— which means one can save electricity or avoid unnecessary alarm alerts by switching them off during the day time, and turn them on again during the night time when danger is most.

- Control Panels

Remote access to your system is vital. Thus, installing appropriate control panels all over the site will enable you to access your system from all areas. Keeping the master panel at a place which is hard to reach for any attacker becomes essential. Most of the panels have been installed with a two ways intercom which facilitates talks with company's security monitoring point. What it means is that if your security measures get activated, you can communicate with one security specialist to elaborate the exact situation. This form of open communication systems provides to you the allowance to receive help faster, or make understand the security officer in-charge of the security system if it has been engaged accidentally.

- Surveillance Cameras

Almost every building has various areas on the outward and inward that serve as good places to hide for attackers. Installing digital cameras inside the area can lessen the number of hiding places that an attacker can hide in, as well as discourage customers and employees from larceny or various inapt behaviors. This becomes a superior form of security service, and with self-integrated alarms and camera system monitoring services, one can be assured that a suspicious activity is reported and dealt with quickly. It is advisable to talk to a specialist when making any sort of final decision for what category of security is best for your firm, depending on the scale that your business operates at.

2.2 Programming, Hardware and Software tools

A) PIR Sensor

The PIR (Passive Infra-Red) sensor is nothing but a pyroelectric device that identifies motion by recording alterations in the evidenced infrared levels that are emitted from the surrounding objects. The various forms of motion can be easily detected by checking on a signal I/O pin on a high signal. PIR sensor is an electronic device which is used in some security systems to detect an infrared emitting source [1]. All living beings whose temperature is anything above absolute zero (-273.15°C or -459.67°F), do emit infrared radiation. This form of energy is completely invisible to the human eye but it can readily be observed by electronic devices that are designed for this purpose. The term used is "passive" in such an instance since PIR does not emit any energy. It merely sits passively and accepts infrared energy waves through windows in the house or industry. The Passive Infrared PIR Sensor modules are moderately priced and now available in the market. Upon using such pre-configured and readymade PIR sensors, any average mind will be able to construct own Motion Sensor Unit. What this paper presents is dependent on a very common and widely known PIR SB0061, which is priced below 500 INR. These PIR devices can readily identify any person attempting to enter a detection zone. Even the slightest of thermal radiation changes in respect to the background triggers the sensor element. It does allow interference among neighboring units because of passive nature of detection principle. [10] The usage of dual-channel sensor technologies and/or advanced digital signal processing lowers wrong alarms that can be caused by turbulence. In the same way, precision optics efficiently defines field of view, granting constant and long coverage area.

- Working of Passive Infr

Red Sensor All PIR sensors will identify alterations in the infra-red radiation, in forms of the heat emitted by several bodies that includes human being, cars and other animals. The larger the body, the higher the infra-red radiation emitted. This becomes easier for a PIR sensor to suspect. The field of view is an area under which alterations in infra-red radiation can be noted. Whereas, range of view can change with modifications in temperature and size of the source of heat. Every zone is regularly monitored by the PIR sensor. Whenever a person or other heat source sneaks into a zone, the infrared radiation level increases. This change gets identified by PIR sensor, and it turns on the connected Transistor and initiates the built-in "Time" process. Given the heat source keeps moving within field of view, PIR sensor continues processing changes in infra-red radiation. When a person stands inside the field of view or exits the detection area, sensor won't measure any change in the infra-red radiation between zones. Thus, the lights will turn off immediately after the "Time" period is finished.

- PIR Sensors to Microcontroller Interface Circuit

In order for the sensor to be most effective in detecting changes of heat among different zones, it is highly advisable for a person to walk across the zones instead of walking

INTERNATIONAL JOURNAL FOR ADVANCE RESEARCH IN ENGINEERING AND TECHNOLOGY

WINGS TO YOUR THOUGHTS.....

along or up a zone. The PIR sensors work passively and they won't radiate any sort of energy beam.

PIR325 Infrared Pyroelectric Sensor

| SPECIFICATIONS | DIMENSIONS |
|-----------------------|------------------|
| ELEMENT SIZE | 2 X 1,2 elements |
| SPECTRAL RESPONSE | 5 ~ 14 |
| NOISE | 20 |
| OUTPUT | 3900 |
| OFFSET VOLTAGE | 1.0 |
| SUPPLY VOLTAGE | 2.5 ~ 15 |
| OPERATING TEMPERATURE | -30 ~ 70 |
| STORAGE TEMPERATURE | -40 ~ 80 |

- NOTES:**
1. With built-in window filter
 2. After 72 db amplifier gain
 3. At source pin 2 with 5 volts and 100K load
 4. Well filtered power supply

Figure 1: PIR specifications

B) Gas and Smoke Sensor

This sensor is used to detect the gas leakage and smoke occurring in home industry or in malls. This is used to detect gases like LPG/ibutane/propane/methane/alcohol/hydrogen/smoke. There are different types of gas sensor which detects different gases according to different concentration parameter. Here we are using MQ-5 & MQ-2 gas and smoke sensors which detect coal gas/ methane/ LPG and combustible gas/smoke respectively.

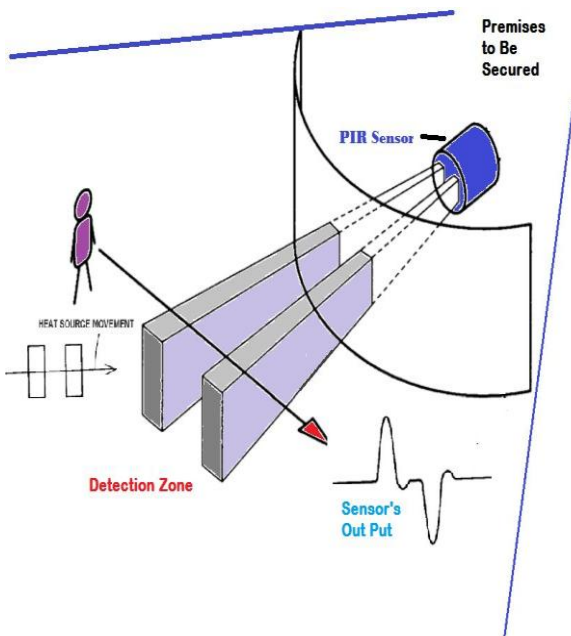

Figure 2: Gas and smoke detector

C) Fuse Failure Detector

Fuse failure detector is a special type of sensor, which will be activated when the security area's fuse breakdown by some unwanted person or by artificial means. During these conditions, fuse failure detector will send the active low signal to microcontroller. At normal condition the IC (MCT2E) between the pin 4 and 5 will be open and the microcontroller pin 36 will be high. When the failure of fuse

occurs, the IC (MCT2E) pin 4 and 5 will be closed and microcontroller pin 36 will be zero. The IC (MCT2E) will also provide isolation between power and control circuits.

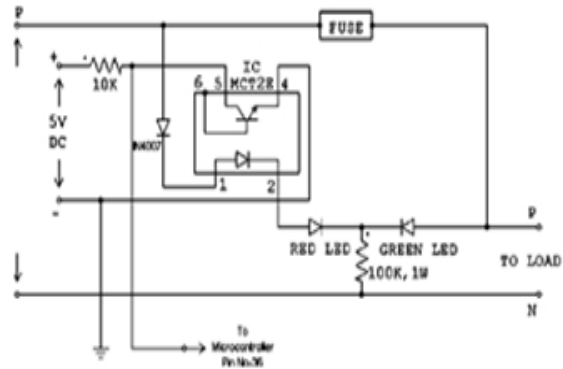

Figure 3: Fuse Failure Detector

D) GSM modem

GSM (Global system for mobile communication) is a cellular network. GSM network operate in four different frequency ranges. Most GSM network operates in bands of frequency of 900 MHz or 1800 MHz. Transmission power in handset is restricted to 2 watts GSM 850/900/300 and 1watt in case of 1800/1900. The biggest distance that GSM specification supports is 35Km (22 mi). In this paper we use SIM300 based GSM modem to receive and send short message to user and system.



Figure 4: GSM modem

E) Relay and Buzzer Interface Circuit

An electromagnetic relay is a type of electrical switch controlled by an electromagnet. Electromagnetic relay is used to control electrical appliances presented in home based on user instruction. The buzzer is used to make warning sound against gas and smoke detection. The microcontroller has insufficient drive capability on output, so there are many ways to drive relays. Relays are normally controlled by a transistor or a driver Integrated Chip for example ULN2003. The driving current for every relay and buzzer is needed at about 60milliAmperes at +12 Volts supply. An array of Darlington transistor, that is, ULN2003 is used to enhance the driving capacity of respective microcontroller. The ULN2803 is of 12V TTL, CMOS devices. It internally employs high voltage, high current. Each Darlington arrays contains seven open collectors. The Darlington combines itself with emitters; each of which channel is rated at almost 500mA and they can tolerate peak currents of up to 600mA. The suppression diodes are involved for some inductive load

INTERNATIONAL JOURNAL FOR ADVANCE RESEARCH IN ENGINEERING AND TECHNOLOGY

WINGS TO YOUR THOUGHTS.....

driving. The inputs get pinned opposite to the outputs to simplify board layout.

emit and receive radiations actively. It, in fact, accepts infrared radiations only passively.

We use a device that contains one special filter. It is known as a Fresnel lens. It focuses the infrared signals on the respective element. Whenever there is a rapid change in ambient infrared signals, what the amplifier does is that it trips output in order to indicate that there is a motion. It can be said that the PIR sensor is comparable to a human body sensor as it is activated if and only if a human or an animal traverses the sensor. Therefore, this PIR sensor becomes the heart of our project. It is possible for us to design the project in a way such as when a burglar or attacker approaches the sensor, the alarms immediately turns on resulting in the entire lighting system turning on.

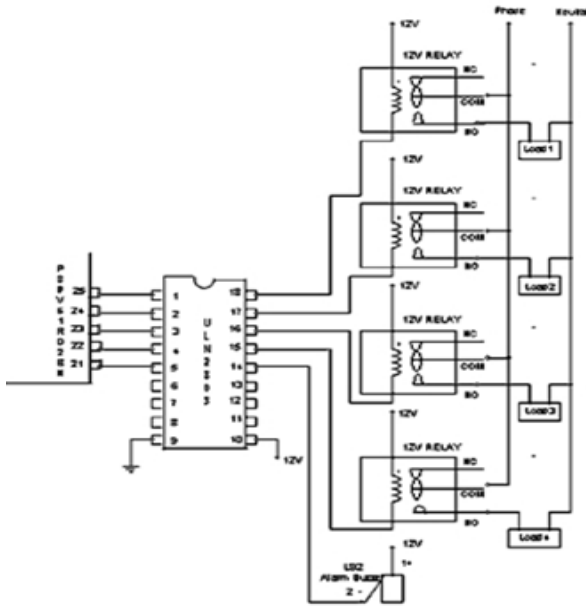

Figure 5: Relay and Buzzer Interface Circuit

3. DRAWBACKS OF THE EXISTING SYSTEM

- Does not contain PIR sensor
- Provides protection only to one specific area and not the entire area.
- Does not work in case of power failures.
- Less reliable.

4. NEW PROPOSED SCHEME

PIR sensor gives complete protection to the area to be protected. Even in the case of power cut, this system will work because of rechargeable batteries used as Power Source. In case of attempt of entry inside the protected area Phone call till answered, and a SMS messages will be forwarded to the owner making him alert of the situation without fail. Instead of using an infrared or laser pair of transmitter-receiver, the PIR (Passive Infrared Radial) sensor is deployed. The PIR sensor is basically nothing but a pyroelectric device. Whenever the device is exposed to an infrared radiation, the sensor transmits an electrical charge. It composes of crystalline material. Based on the variation in the quantity of infrared radiation that strikes an element, a change in voltages will be generated, that is recorded by an amplifier on-board.

The infrared light mentioned here means the light that is radiating from objects within the field of view. The only reason of not keeping a transmitter and receiver is because the device doesn't itself emit energy signals. It just accepts the energy that is emitted from the objects above an absolute zero in the forms of radiation. Therefore, the temperature will not be the same for the humans working past sensors, and that of a wall lying before it. Hence, the word "passive" has been utilized in PIR sensors to elaborate that it doesn't

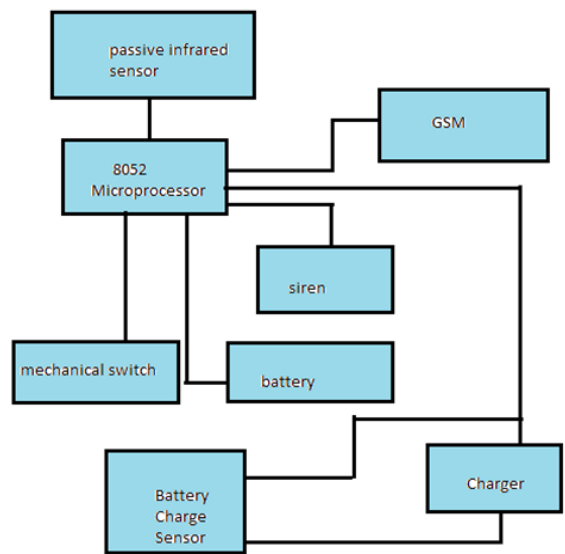

Figure 6: A block diagram of the PIR-based system

The system is fully controlled by the microcontroller and the microcontrollers will continuously monitors the sensors, detector and GSM modem. If the voltage level of sensor input pins goes to zero then it will send the "AT + CMGS = "USER MOBILE NUMBER" to GSM modem through serial port. The GSM modems will response with the character ">". After receiving ">" Character microcontroller again send the type of security problem SMS + CTRL Z to GSM Modem. GSM modem will send the type of problem to user. For example any moment detected in security area at the time microcontroller pin number 39 goes to logical zero. Microcontroller sensed the change and immediately send AT + CMGS = "+888888888888" to GSM modem, GSM modem give ">" character to microcontroller. After receiving ">" Character microcontroller again sends the "MOMENT DETECTED" SMS to GSM Modem. GSM modem sends the SMS to user. When a new SMS arrived, the GSM modem would send the AT + CMTI: "SM", 1 byte stream to microcontroller, To read the message, The microcontroller send the command AT + CMGR = 1 to GSM modem. The GSM modem will respond with something similar to the following: + CMGR: "REC UNREAD", "+888888888888", "08/08/09 18:20:35 + 00", + CR + LF USER SMS OK. The first part is the command + CMGR, the second part is the status of the message, the third portion is

INTERNATIONAL JOURNAL FOR ADVANCE RESEARCH IN ENGINEERING AND TECHNOLOGY

WINGS TO YOUR THOUGHTS.....

the sender's mobile number, the fourth portion is the base station time-stamp, followed by the carriage return and line feed characters, the message content, and finally the "OK" terminating character. After receiving SMS, the microcontroller takes necessary action based on user SMS [9]. For example, user sends the SMS "Light One On" to GSM modem number, GSM modem receives the SMS and sends AT + CMTI: "SM" to microcontroller. After receiving the command, microcontroller will send text message read command "AT + CMGR = 1" to GSM modem, after receiving read command, microcontroller sends received message in the format of + CMGR: "REC UNREAD", " + 888888888888", "08/08/0918:20:35 + 00", Light one on OK. After receiving original message, microcontroller will skip all the characters before the six inverted commas, then will read the original message and verify with preloaded user message then make pin number 25 to high.

Waveform of Sensors and Microcontroller input in the sensors are in ideal position, the input of the microcontroller remains nearly 5V which is considered as logical one by microcontroller. When the sensors are activated, the voltage across base emitter (VBE) of the transistor increases which makes transistor to turn on. Now the voltage across the collector emitter (VCE) of the transistor is 250mV, which in turn serves as an input for microcontroller. As the logical low value of the microcontroller is 800mV but the input from the transistor is of low range, it is considered as logical zero.

4.1 Capturing of image using PIR sensor and camera

Recent improvements in component technologies mean that it is now possible to design a camera, wireless transmitter and flash within a PIR sensor that too only with a small increase in the size of the end product. By taking still or moving pictures of the intruder, compressing them and then uploading the images to a central server, the sensor greatly strengthens its deterrent effect against intruders by providing evidence, which can be used against the perpetrator. This adds a large amount of value to the end product, but without a correspondingly large increase in the bill of materials. The chief challenges involved in implementing such a design are, first, to keep the physical size of the product to a minimum; and second, to limit power consumption so that it can run for extended periods on battery power. As this article will show, both of these challenges can be met by using the latest generation of components. The main principles of the design approach taken here are: To use highly integrated ICs, eliminating peripheral components and thus reducing footprint

Ideas for adding value to simple intruder alarm systems. New image sensor, alarm enhancer and radio components to enable enhanced intruder detection designs to keep large sections of the system in sleep mode except when an intruder is detected. This means that the power-hungry elements of the system get activated, such as the short-range radio and image processing, only operate at full power in short, infrequent bursts.

The ePIR solution uses a software algorithm for signal conditioning, running on a microcontroller from ZiLOG's Z8 Encore! XP family. In this intruder alarm design, the 8-pin Z8F042ASB020SG device would be suitable. No external

gain or filtering circuitry is required, which dramatically reduces component count. At the same time, an ePIR design will offer excellent immunity to false alarms and noise, high reliability and integrated compensation for environmental effects. Because there is no filter, there is no loss of signal, which results in improved range and coverage. The total cost of an ePIR-based circuit is cheaper than a traditional all-analogue PIR sensor circuit that offers improved performance as compared to high-end digital PIR sensor systems are able to provide. An alternative approach to integrating the analogue signal-conditioning circuitry is to use a member of the PSoC (Programmable System-on-Chip) family of devices from Cypress Semiconductor. PSoC devices are mixed-signal arrays of configurable digital and analog blocks, controlled by an on-chip 8-bit core. The blocks can be configured to fulfil standard peripheral functions such as analogue-to-digital converter, timer and UART. But the value of PSoC is its ability to also integrate sophisticated analogue functions such as filters and amplifiers. The analogue functions of the conditioning circuit outlined in Figure 2 can be integrated in the PSoC, meaning that a complete solution comprising the PIR sensor, PSoC and a handful of tiny passive components can be realized (see Figure 4). Furthermore, like the ePIR implementation, the solution can be streamlined to fit into an 8-pin device. Such an implementation leaves processing bandwidth to spare to control the downstream system functions: activating the image sensor, power LED and image processor, and operating the short range radio.

4.2 Secure Storage

The enhanced, compressed images now need to be sent to a central server for secure storage, where they cannot be tampered with by an intruder. The main design challenge is, again, to provide this functionality with a miniature, power-efficient device. The data rate requirement is quite moderate. JPEG typically achieves a 10:1 compression ratio with little perceivable loss in image quality. This means that a typical 500kB image file could be compressed to 50kB, and transmitted in 2s at 250kbit/s, even with a prudent allowance for overhead. A sensible approach would be to buffer images in a small Flash memory on activation of the sensor, bringing the NAND Flash interface in the BU6569GVW into play, and then stream them to the server. Operating in Europe's unlicensed 433MHz and 868MHz bands, Micrel's MICRF505/6 transceiver comes in a 5mm² MFL package. It provides a data-rate up to 200kbaud and draws 28mA in transmit mode. The use of just a transmitter would give a small saving in board space and power, whilst a transceiver would allow for confirmation of receipt of transmitted images. Bearing in mind the application, the risk of failed transmission is not worth taking: the system might only ever be called on to operate once – when it does, the user will expect it to work flawlessly. For end products that are to be marketed worldwide, the 2.4GHz frequency is more suitable. Here, Freescale's MC13202 is compatible with the IEEE 802.15.4 standard and has an over-the-air data rate of 250kbps using Direct Sequence Spread Spectrum (DSSS) coding for interference immunity.

INTERNATIONAL JOURNAL FOR ADVANCE RESEARCH IN ENGINEERING AND TECHNOLOGY

WINGS TO YOUR THOUGHTS.....

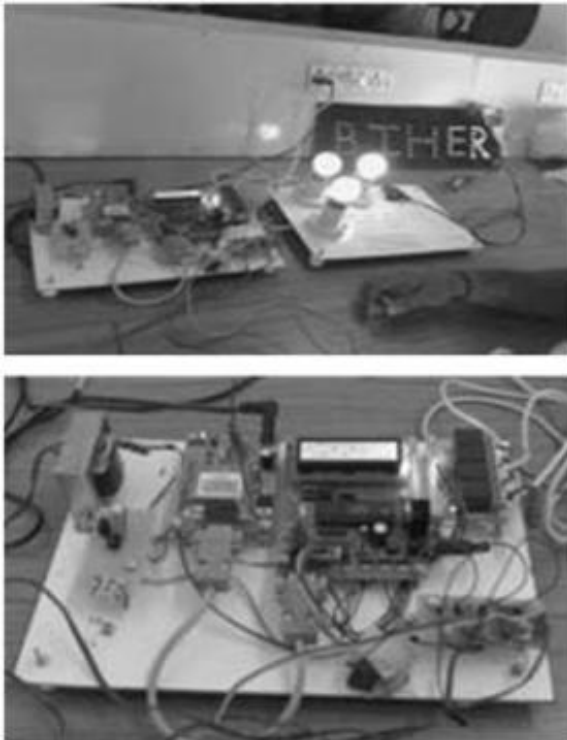

Figure 7: Secure Storage

5. CONCLUSION

The proposed security system is more advanced than the ones used previously due to various reasons. To spot a few, they are -

- PIR SENSOR gives complete protection to the area to be protected
- Even in the case of power cut, this system will work Because of Rechargeable batteries used as Power Source.
- In case of attempt of entry inside the protected area Phone call till answered, and a SMS messages will be forwarded to the owner making him alert of the situation without fail.

REFERENCES

- [1] Zappi P., Farella E., Benini L., "Hydroelectric Infrared Sensors based Distance Estimation", Dept. of Electron, Inf. & Syst., Univ. of Bologna. IEEE Publication, (2008) 716-719.
- [2] Hosticka, B. J., "Analog Circuits for Sensors" Inst. Of Fraunhofer Microelectron. Circuits & Syst., IEEE Publication, E-ISBN: 978-1-4244-1124-5, (2007) 97-102.
- [3] Al-Ali A. R., Rousan M. A., Mohandes M., "GSM-based Wireless Home Appliances Monitoring & Control System", IEEE International Conference, ISBN: 0-7803- 8482-2, (2004) 237-238.
- [4] Shubha Kadambe, "Signal Processing and Feature Extraction Toolbox for Prognosis/Diagnosis". Autotestcon, IEEE Publication, ISBN: 0-7803-9101-2, (2005) 431-437.
- [5] Moshiri B., Khalkhali A. M., Momeni H. R., "Designing a Home Security System Using Sensor

Data Fusion with DST and DSMT Methods". Tehran Univ., Tehran; IEEE Publication, (2007) 1-6.

- [6] Ying-Wen Bai, Shi-Chang Chen, Fu Jen, "Design and Implementation of Home Intercom and Security Control Systems for Buildings" Catholic Univ. Information Fusion, 2007 10th International Conference on Publication, ISBN: 978-0-662-45804-3, (2007) 1-6.
- [7] R. Hariprakash, G. Venkatramu, S. Ananthi, "University of Madras, K. Padmanahan "Some Problem and Methods for Remotely Controllable Automatic Home Security System" Systems and Networks Communications. ICSNC, 3rd International Conference Publication, ISBN: 978-0-7695-3371-1, (2008) 400-403.
- [8] Rosendahl A., Botterweck G., "Univ. of Koblenz-Landau, Koblenz "Mobile Home Automation-Merging Mobile Value Added Services and Home Automation Technologies", International Conference on the Management of Mobile Business (ICMB 2007), ISBN: 0-7695-2803-1, (2007) 31.
- [9] Wuhan, China, "An Improved Short Message Security Protocol for Home Network" Industry Applications Society Annual Meeting, Conference Record of the 1994 IEEE Publication, ISBN: 0-7803-1993-1, 3 (1994) 2121-2125.
- [10] Litton C. D., Vinson R. P., "Application of the Diesel, R. Anandan et al, Journal of Global Research in Computer Science, 4 (4), April 2013, 126-132 © JGRCS 2010